

MEGATRON® MODEL 6N

INSTALLATION ADJUSTMENT SERVICE COMPLETE WATER TEMPERATURE CONTROL STATION

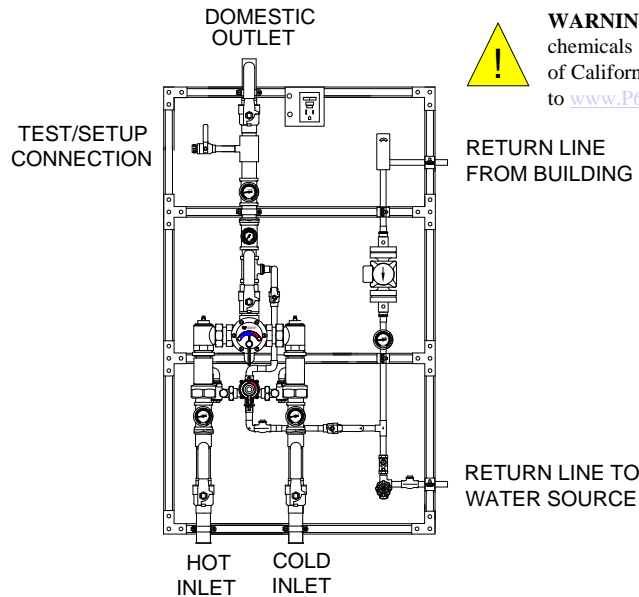

WARNING: This product can expose you to chemicals including lead, which is known to the State of California to cause cancer. For more information, go to www.P65Warnings.Ca.gov

1. Type TM manifold systems are factory pre-assembled and tested and include large and small thermostatic water mixing valves which function as a system to meet both high and low demand for tempered water.
2. System should be installed at a location where it can easily be cleaned, adjusted or repaired.
3. System supplies must be connected as shown (Hot-left, Cold-right). Connect return piping as shown. Exercise caution when soldering
4. Flush pipes thoroughly after system has been connected.
5. Refer to page 3 & 4 of this bulletin for correct Setup Instructions.

Maximum Operating Pressure 125PSI (860kpa) for Hot and Cold Water



All thermostatic water-mixing valves have limitations. They will not provide the desired accuracy outside their flow capacity range. Consult the capacity chart on page 8. Minimum flow must be no less than as shown.

REMEMBER! THIS IS A CONTROL SYSTEM WHICH MUST BE CLEANED AND MAINTAINED ON A REGULAR BASIS (SEE MAINTENANCE GUIDE AND RECORD MGR-1000).

ADJUSTMENT AND SERVICE

Leonard Type TM Thermostatic Water Mixing Valves are simple in design and may be easily cleaned, adjusted and repaired. If the installation is accessible, servicing may be completed without disconnecting the valves.

NOTE: High Low Manifold Systems include Thermostatic Water Mixing Valves, which must be regularly maintained to provide best performance. Frequency of cleaning depends on quality of local water conditions and usage. See Maintenance Guide and Record MGR-1000.

WARNING

These mixing valves are equipped with an adjustable high temperature limit stop factory set at approximately 120°F (49°C) with an incoming hot water supply temperature of 150°F (65.5°C). If the hot water supply temperature of the job is greater than 150°F (65.5°C), the valves when turned to full HOT will deliver water in excess of 120°F (49°C) and, the limit stops, **MUST BE RESET BY THE INSTALLER!**

TO RESET ADJUSTABLE HIGH TEMPERATURE LIMIT STOP:

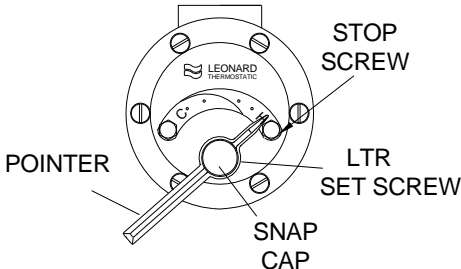
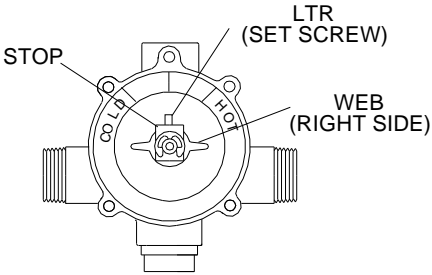
LARGE MIXING VALVE	SMALL MIXING VALVE
	
<ol style="list-style-type: none"> 1. Loosen LTR screw 2. Remove SNAP CAP, SCREW & WASHER Remove POINTER. 3. Temporarily place POINTER on the spline rod, turn RIGHT for warmer temperature, turn LEFT for cooler temperature. When valve is delivering warmest temperature desired, remove the pointer. 4. Replace POINTER on the spline rod so that its RIGHT edge is resting against the WEB located on the RIGHT SIDE OF THE COVER. 5. The new maximum temperature has now been set. Test this temperature by holding a thermometer under the flow of water to be certain it is as desired. 	<ol style="list-style-type: none"> 1. Remove POINTER, RETAINING RING and STOP 2. Loosen LTR screw. 3. Temporarily place POINTER on the spline rod, turn LEFT for cooler temperature, turn RIGHT for warmer temperature. When valve is delivering warmest temperature desired, remove the pointer. 4. Push stop on rod so that its RIGHT edge is resting against the top side of the web, which is cast on the RIGHT SIDE OF THE COVER. 5. Replace stop retaining ring. 6. Replace POINTER so that it is pointing to the extreme HOT position. The new maximum temperature has now been set. Test the temperature by holding a thermometer under the flow of water to be certain it is as desired.

IMPORTANT! BOTH MIXING VALVES MUST BE SET AT THE SAME OPERATING TEMPERATURE.

SEE PAGES: 6 & 7 FOR COMPLETE PARTS BREAKDOWN

Check for significant variations in outlet flow. Thermostatic valves will NOT provide the desired accuracy outside of their flow capacity range. Minimum flows must be no less than shown (see Flow Capacities, page 8).

If installed on a recirculated hot water system, make certain the valve is piped according to Leonard Required Piping Method #2 PRV (see page 3).

REMEMBER! THIS IS A CONTROL DEVICE WHICH MUST BE CLEANED AND MAINTAINED ON A REGULAR BASIS. (SEE MAINTENANCE GUIDE AND RECORD, MGR-1000).

SETUP INSTRUCTIONS

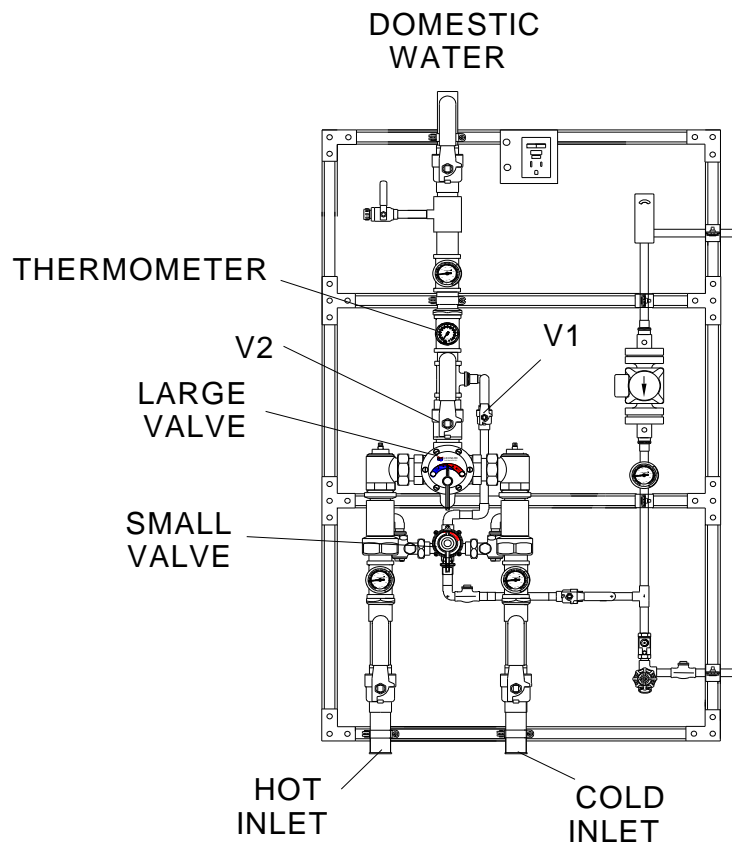

1. The High-Low Unit **MUST** be piped according to Method #2 (see page 4).
2. Make sure full hot and cold supplies to this assembly are operating. The temperature of the hot water source must be properly set and maintained.
3. The circulator (if used) must be turned **OFF** before setup.
4. Turn on enough fixtures for a flow of at least 30 GPM (114 l/min.) downstream from this system. Make sure each fixture is set to deliver full "HOT" water.
5. Close outlet Valve V1 at the smaller Type TM Valve
6. Make sure Valve V2 at the large Type TM Valve is in the full open position.
7. Set outlet temperature of the large Type TM Valve to the required level.
8. Open outlet Valve V1 at the small TM Valve.
9. Shut outlet Valve V2 at the large TM valve.
10. Turn off enough fixtures for a flow of at least 2 GPM (7.6 l/min) downstream from this system.
11. Make sure each fixture is set to deliver full "HOT" water.
12. Set outlet temperature of the small TM valve to the same temperature as the large TM Valve.
13. Open outlet Valve V2. System is operational.
14. See page 4 to balance recirculated system.

* NOTE! FOR OPTIONAL OUTLET SETUP PIPING ARRANGEMENT, SEE PAGE 5

REQUIRED METHOD OF PIPING (RECIRCULATED DOMESTIC WATER SYSTEMS)

METHOD #2

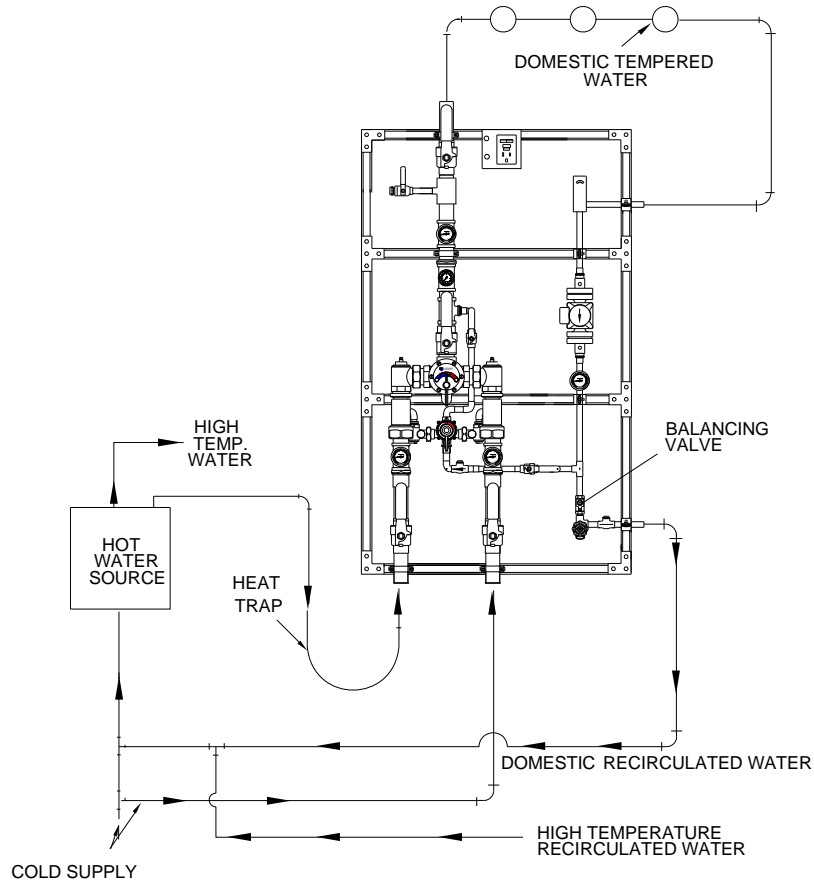

THIS PIPING METHOD IS NOT TO BE USED FOR MORE THAN ONE BUILDING

PROCEDURE TO BALANCE RECIRCULATION SYSTEM

1. MAKE SURE NO WATER IS BEING DRAWN IN THE BUILDING. OPEN BALANCING VALVE APPROXIMATELY HALF WAY, AND START CIRCULATOR.
2. OBSERVE TEMPERATURE UNTIL IT STABILIZES.
3. CLOSE BALANCING VALVE SLIGHTLY IF TEMPERATURE IS TOO HOT, OR OPEN IT SLIGHTLY IF TEMPERATURE IS TOO COLD AND ALLOW TEMPERATURE TO STABILIZE. REPEAT UNTIL DESIRED RECIRCULATED TEMPERATURE IS SET.

REMEMBER! THIS IS A CONTROL DEVICE WHICH MUST BE CLEANED AND MAINTAINED ON A REGULAR BASIS (SEE MAINTENANCE GUIDE AND RECORD, MGR-1000).

METHOD #4
CIRCULATED FLOWS BETWEEN
8-25 GPM

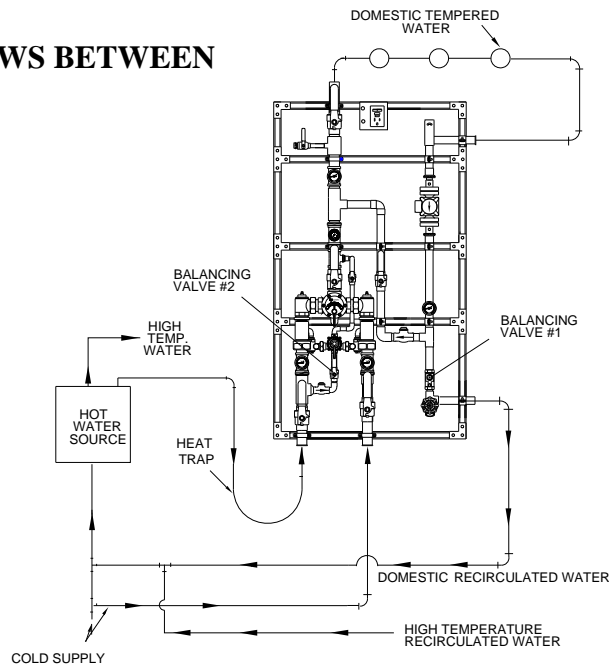

PROCEDURE TO BALANCE SYSTEM:

- MAKE SURE NO WATER IS BEING DRAWN. OPEN VALVE #1 AND VALVE #2 APPROXIMATELY ½ WAY AND START CIRCULATOR.
- OBSERVE TEMPERATURE UNTIL IT STABILIZES.
- CLOSE VALVE #1 SLIGHTLY IF TEMPERATURE IS TOO HOT, OR OPEN IT SLIGHTLY IF TEMPERATURE IS TOO COLD AND ALLOW TEMPERATURE TO STABILIZE. REPEAT UNTIL DESIRED TEMPERATURE IS SET.
- IF UNABLE TO REACH DESIRED TEMPERATURE OPEN VALVE #2 FULL, REPEAT STEPS 2 AND 3.

METHOD #5
CIRCULATED FLOWS GREATER
THAN 25 GPM

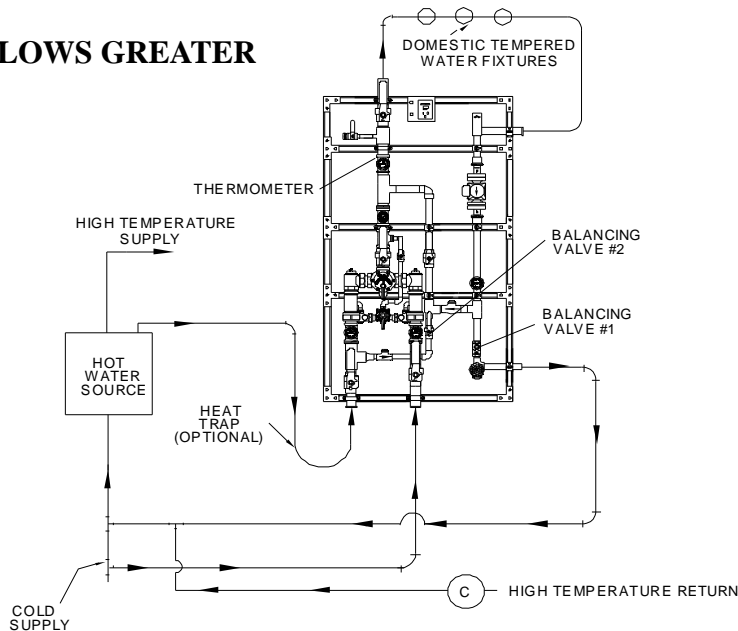

PROCEDURE TO BALANCE SYSTEM:

- MAKE SURE NO WATER IS BEING DRAWN. OPEN VALVE #1 AND VALVE #2 APPROXIMATELY ½ WAY AND START CIRCULATOR.
- OBSERVE TEMPERATURE UNTIL IT STABILIZES.
- CLOSE VALVE #1 SLIGHTLY IF TEMPERATURE IS TOO HOT, OR OPEN IT SLIGHTLY IF TEMPERATURE IS TOO COLD AND ALLOW TEMPERATURE TO STABILIZE. REPEAT UNTIL DESIRED TEMPERATURE IS SET.
- IF UNABLE TO REACH DESIRED TEMPERATURE OPEN VALVE #2 FULL, REPEAT STEPS 2 AND 3.

INSTRUCTIONS FOR SERVICING LARGER TM VALVE

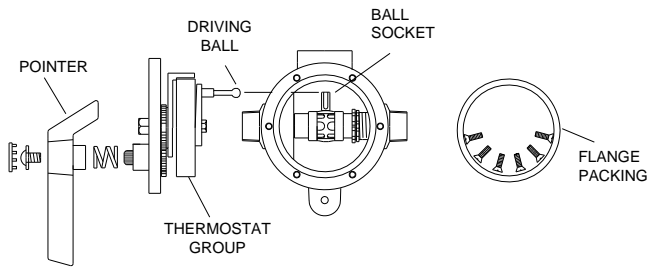

1. Loosen LTR set screw.
2. Remove snap cap, screw and washer, friction spring and pointer.
3. Turn off hot and cold supplies at screwdriver checkstops. Remove M20-2C cover screws to release cover and thermostatic control assembly.
4. To clean port sleeve assembly, (the thimble must move freely on the port sleeve): unscrew the check nut as far as it will go, then screw the port sleeve nut into the base. The port sleeve and thimble may be lifted out. SEE DWG "A".
5. Clean in a non-corrosive cleaning solution. **DO NOT USE ABRASIVES!**

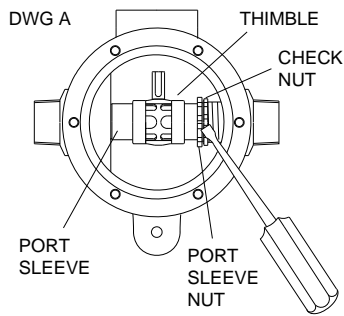

6. To clean thermostat group, remove coil sleeve stud and take off thermostat group.
7. Clean in a non-corrosive cleaning solution.
8. When reassembling, make sure driving ball of thermostat group engages the ball socket of the port sleeve assembly.

INSTRUCTIONS FOR SERVICING SMALLER TM VALVE

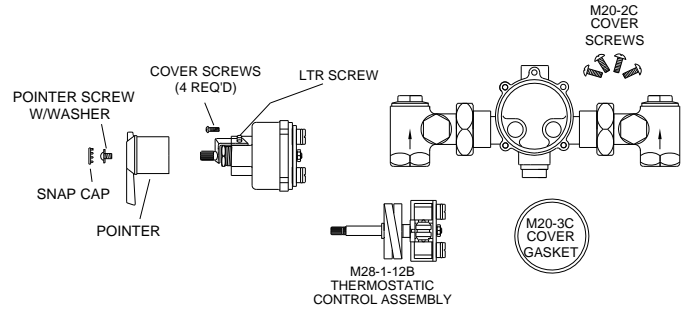

1. Remove screw, snap cap, and handle.
2. Loosen LTR set screw
3. Turn off hot and cold supplies at screwdriver checkstops. Remove M20-2C cover screws to release cover and thermostatic control assembly.
4. To remove bridge assembly, TM-28-1-8B, remove pointer rod nut (M20-10B) and pull bridge assembly off control rod.

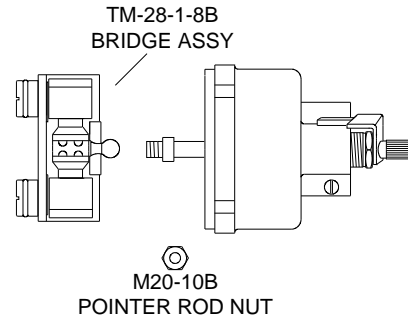

5. To disassemble bridge assembly, see drawing next page (remove M20-5B holder nuts with screwdriver in slots provided).
6. Remove thermostat group from bridge assembly, and soak in a non-corrosive cleaning solution.
7. To clean, submerge bridge assembly in clean water or non-corrosive cleaning solution. **DO NOT USE ABRASIVES!** Be certain thimble moves freely on port sleeve. Note! Driving stud (M20-14B) must engage slot in thimble when assembling.

TROUBLESHOOTING INSTRUCTIONS

Note: Provide valve serial number when ordering parts for either valve!

PACKING & GASKETS	Leaks at stem. Leak between valve cover and base.	Large Valve: Kit # 1/200Y	Small Valve: Kit #1/28Y (Packings & Gaskets)
PORT SLEEVE/BRIDGE ASSEMBLY	Valve delivers either all hot or all cold water, or will not mix consistently.	Kit # R/200N	Kit #R/28 (Rebuilding Kit) or TM28-1-8B Bridge Assembly
THERMOSTAT GROUP	After cleaning or replacing port sleeve/ bridge assembly, valve performance is not consistent.	Kit # R/200N	Kit #R/28 (Rebuilding Kit) or TM-28-G2 Thermostat Group
CHECKSTOPS	Hot water by-pass into cold line (or cold into hot). Supplies cannot be shut off completely. Supplies leak at checkstop bonnets.	Kit #2/200Y	Kit #2/28Y (Checkstop Kit)

LARGE TM VALVE PARTS

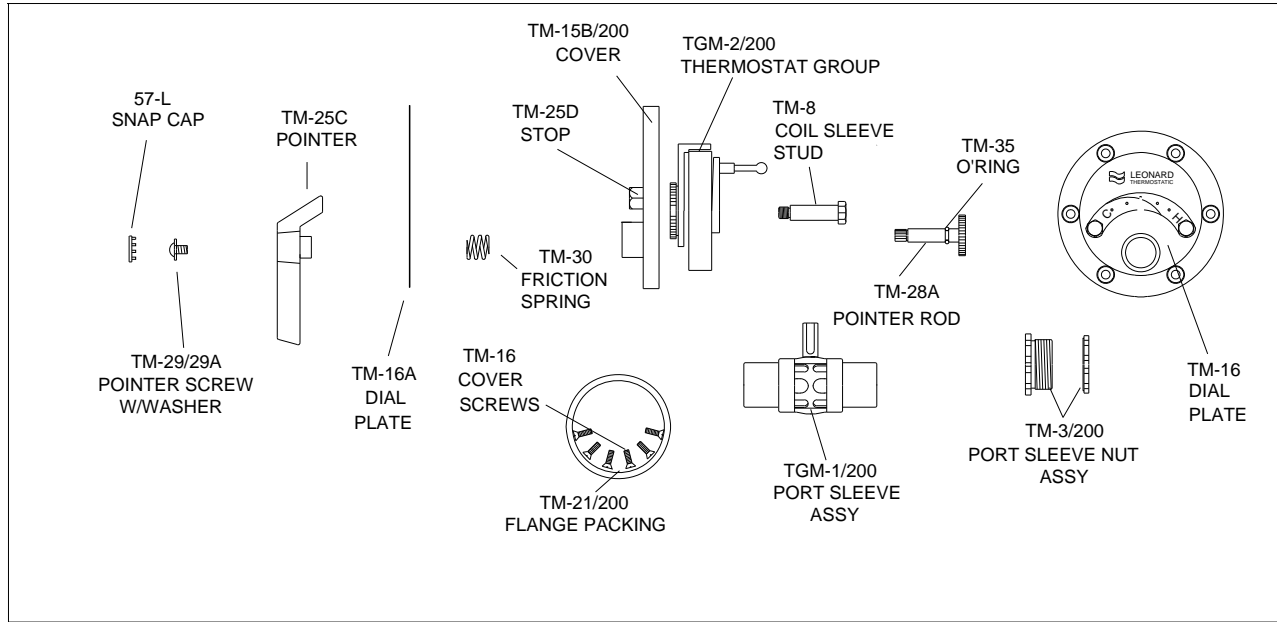

CHECKSTOP PARTS

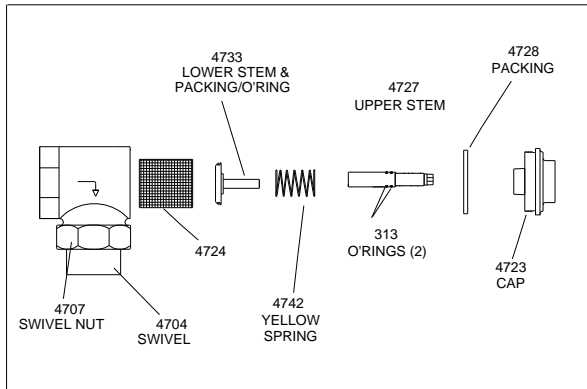

LOCK-TYPE POINTER

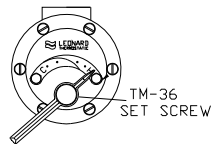

REMEMBER! THIS IS A CONTROL DEVICE WHICH MUST BE CLEANED AND MAINTAINED ON A REGULAR BASIS (SEE MAINTENANCE GUIDE AND RECORD)

NOTE: AFTER INSTALLING NEW PARTS IT WILL BE NECESSARY TO RESET THE ADJUSTABLE HIGH TEMPERATURE LIMIT STOP ON EACH VALVE (SEE PAGE 2).

REPAIR KITS

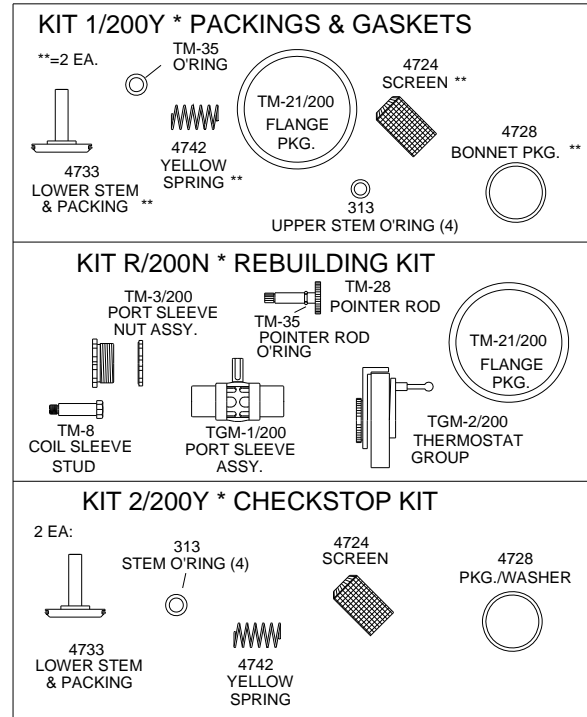

SMALL TM VALVE PARTS

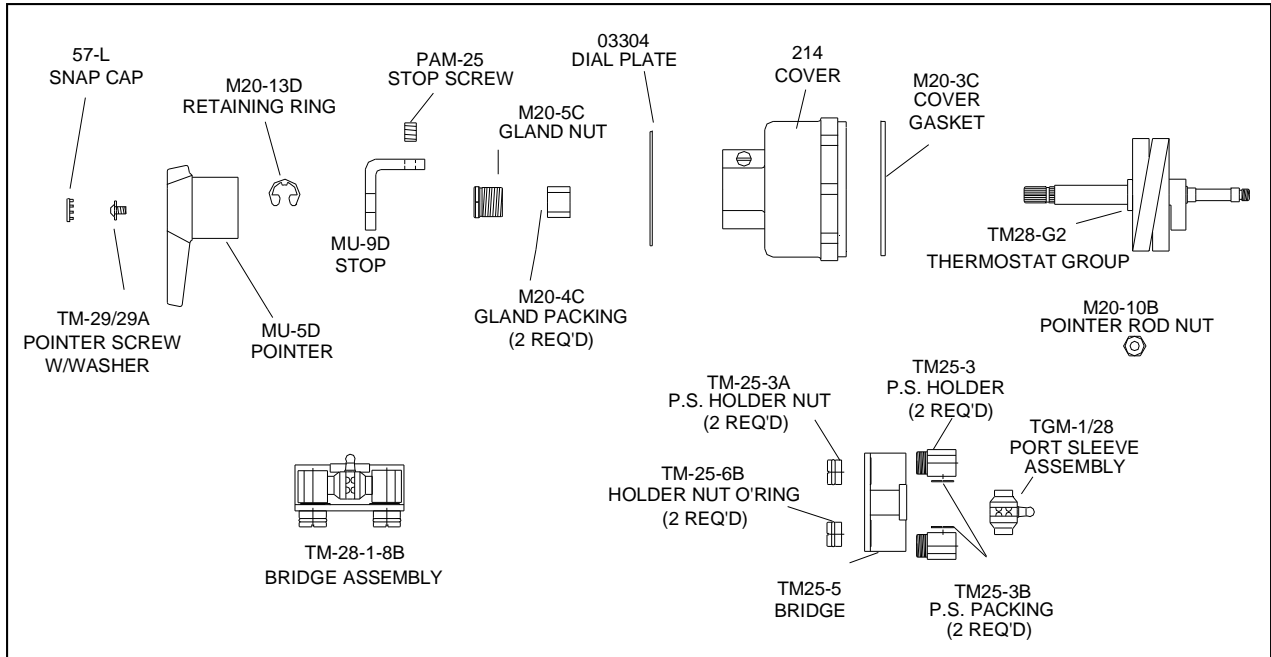

CHECKSTOP PARTS

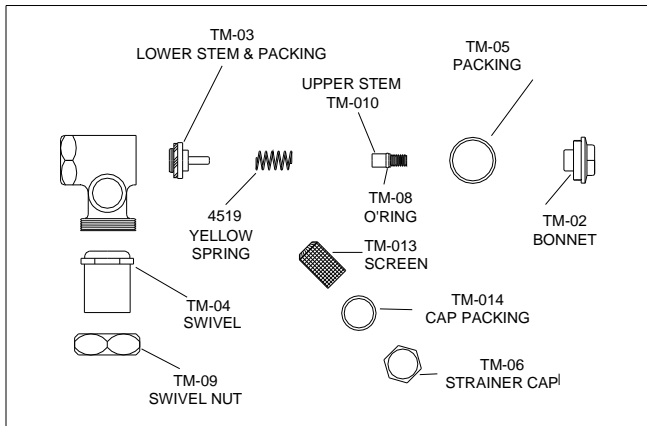

LOCK-TYPE POINTER

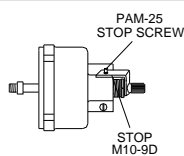

REMEMBER! THIS IS A CONTROL DEVICE WHICH MUST BE CLEANED AND MAINTAINED ON A REGULAR BASIS (SEE MAINTENANCE GUIDE AND RECORD, MGR-1000).

NOTE: AFTER INSTALLING NEW PARTS IT WILL BE NECESSARY TO RESET THE ADJUSTABLE HIGH TEMPERATURE LIMIT STOP ON EACH VALVE (SEE PAGE 2).

REPAIR KITS

KIT 1/28Y PACKINGS & GASKETS

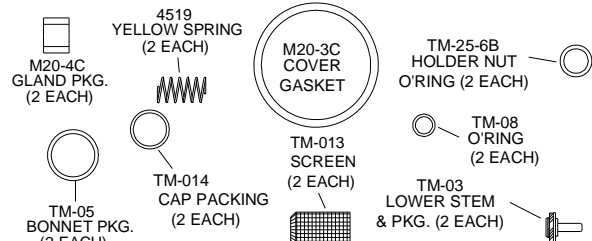

KIT R/28 REBUILDING KIT

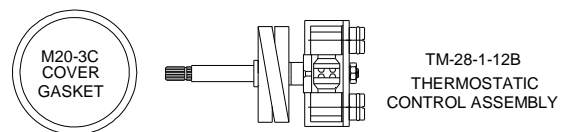

KIT 2/28Y CHECKSTOP KIT

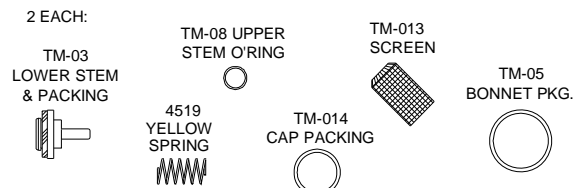

CAUTION! ALL THERMOSTATIC WATER MIXING VALVES AND SYSTEMS HAVE LIMITATIONS! THEY WILL NOT PROVIDE THE DESIRED PERFORMANCE OUTSIDE OF THEIR FLOW CAPACITY RANGE! CONSULT THE CAPACITY CHART BELOW AND OBSERVE MINIMUM FLOWS SHOWN.

FLOW CAPACITIES

MINIMUM FLOW (GPM)	SYSTEM PRESSURE DROP (PSIG)										PSI
	5	10	15	20	25	30	35	40	45	50	
(l/min)	.3	.7	.97	1.4	1.7	2.1	2.4	2.8	3.1	3.4	BAR
1.0	78	113	129	145	163	172	188	197	214	226	GPM
(3.8)	295	428	488	549	617	651	712	746	810	856	l/min

LIMITED WARRANTY

Leonard Valve Company warrants the original purchaser that products manufactured by them (not by others) will be free from defects in materials and workmanship under normal conditions of use, when properly installed and maintained in accordance with Leonard Valve Company's instructions, for a period of one year from date of shipment. During this period the Leonard Valve Company will at its option repair or replace any product, or part thereof, which shall be returned, freight prepaid, to the Leonard factory and determined by Leonard to be defective in materials or workmanship. There are no warranties, express or implied, which extend beyond the description contained herein. There are no implied warranties of merchantability or of fitness for a particular purpose. In no event will Leonard be liable for labor or incidental or consequential damages. Any alteration or improper installation or use of the product will void this limited warranty.